

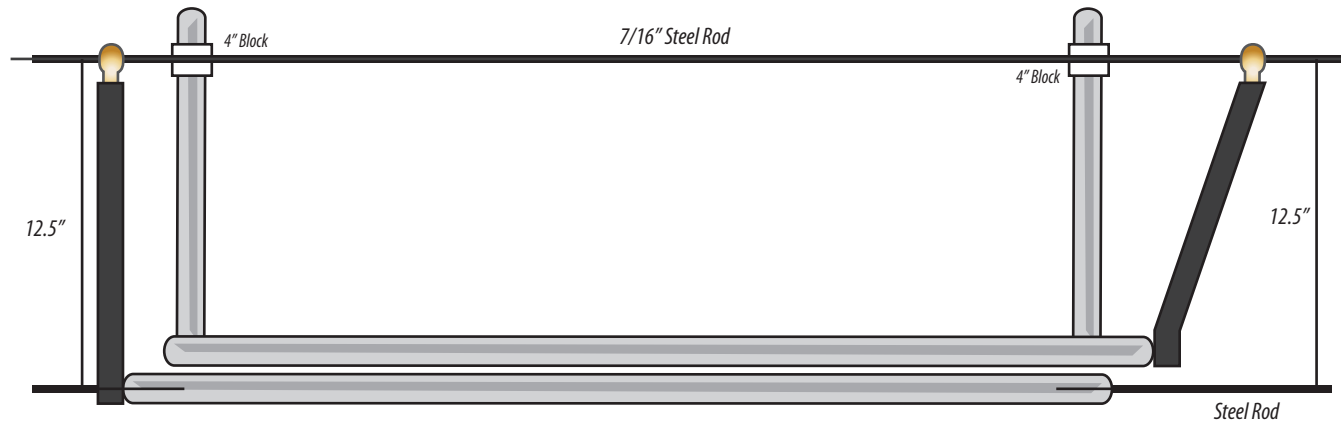

Rear Axle Squaring Guide



LEFT

(top view perspective)

RIGHT

(top view perspective)

Setting the Torsion Arm Lengths

1. Prior to installing the rear axle, insert the rear torsion arms in rear torsion rack (w/ bushings installed)
2. Fasten rear torsion arms (as shown)
3. Insert the 7/16" Steel Rod or the like, through the torsion arm heims to act as an aligning tool, use 4" set up blocks to allow the rod to rest on the blocks
4. Insert the 2nd steel rod through the right rear torsion bar to act as the rear aligning tool
5. Measuring from the center of the front rod, to the center of the rear rod find 12.5" (center line to center line, as shown)
5. Adjust torsion arm heims as need to square the arm lengths

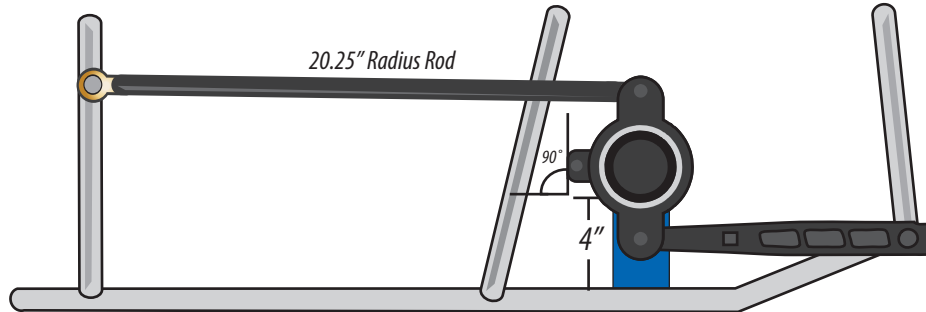

LEFT

(side view perspective)

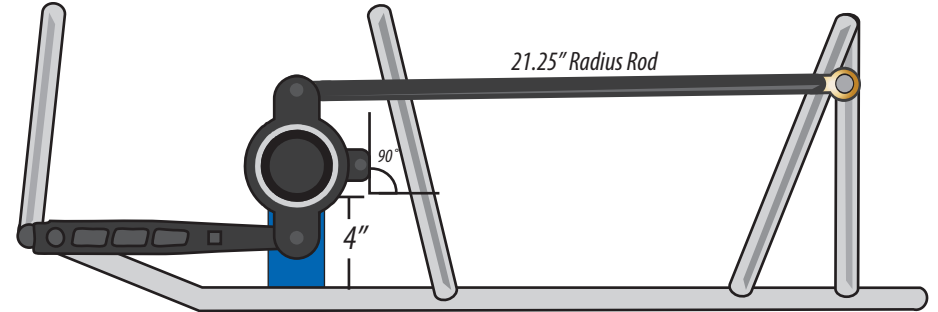

RIGHT

(side view perspective)

Timing the Rear Axle Bird Cages

1. After using the Rear Axle Assembly Sheet to space your rear axle correctly (make sure axle nuts are done up tight), insert the axle in the car on 4" set up blocks
2. Fasten the rear radius rods, brake control rod, and Jacob's ladder to the axle
3. Without torsion stops installed, fasten the rear torsion arms to the rear birdcage pick ups.
4. To time the rear birdcages, use an angle finder on the front portion of the bird cage that is flat (as shown)
5. Find 90° by adjusting the length of the rear radius rods

Notes

DRIVEN